

Certificate of Testing

Certificate Number: 2018/83

Date: 1 May 2018

System: **Mechslip Brick slip system**

System supplier: Ash and Lacy Solutions Ltd
Bromford Lane
West Bromwich
West Midlands
B70 7JJ

Tests performed:

Watertightness – dynamic	✓
Wind resistance – serviceability	✓
Wind resistance – safety	✓
Soft body impact	✓
Hard body impact	✓

In accordance with 'Standard for systemised building envelopes CWCT, 2006



Test Witness



Director

CWCT Services Ltd, The Studio, Entry Hill, Bath, BA2 5LY
Tel: 01225 330945, email: cwct@bath.ac.uk www.cwct.co.uk

Company registered in England at RSM, 25 Farringdon Street, London, EC4 4AB
number 2536548; VAT number: 600 9915 52

Description of system tested

Rainscreen system:	Mechslip brick slip system
Panel material:	Brickmaking clay. Slips available in a variety of colours: tested slips colour code A0181A
Panel description:	Brick slips 215 x 65 x 28 mm with slots cut in top and bottom faces to engage with fixing rails.
Joints: Joints in test wall full depth with bucket handle finish. Parex historic mortar which is a pre-bagged lime based material used for joints. At joints in vertical support rails, the top brick slip of the lower rail restrained by a top bar and the lowest row of slips on the upper bar supported by a start rail. 15mm joint gap between brick slips filled with flexible sealant.	
Support rails: Brick slips supported by extruded aluminium horizontal rails. Rails composed of 6063T6 aluminium and designed to restrain the top of the brick slip below the rail and support the brick slip in the row above the rail. For the test wall, the horizontal rails were supported by vertical L profiles (60 x 40 x 2.2mm). Vertical profiles composed of 6063 T6 aluminium and supported by brackets at 600mm centres. Profiles at 600mm spacing. Brackets supporting vertical rails 80mm high with 120mm projection and provided with insulating pad between baseplate and back wall. One bracket on each section of rail fixed to carry dead load. Remaining fixings between rails and brackets in slotted holes to permit vertical movement. Note: Other methods of supporting the horizontal rails may be used provided the support provided is similar.	
Fixings: Brick slips engage with horizontal rails and locked in position by mortar joints. Horizontal rails fixed to vertical rails with screws, one screw at each intersection. Rails fixed to brackets by screws, two screws per bracket. Screws manufactured by Ash and Lacy and supplied as part of system.	
Drainage and ventilation: Note: The CWCT Standard requires a drained and ventilated cavity in a rainscreen wall which requires openings at the top and bottom of the cavity. The cavity is required to have a minimum width of 25mm. The Standard does not specify the minimum area of drainage and ventilation openings.	10mm diameter drainage holes provided at bottom of test sample.
Backing wall:	Steel studs with plywood sheathing. Back wall provided to facilitate testing but not part of the tested system.

Test arrangements

Date of test:	20 December 2018
Testing laboratory:	Technology Centre VINCI Construction UK Ltd Stanbridge Road Leighton Buzzard Bedfordshire LU7 4QH
Registration No:	UKAS No 0057
Independent testing authority:	Technology Centre VINCI Construction UK Ltd Stanbridge Road Leighton Buzzard Bedfordshire LU7 4QH
Witness:	Alan Keiller CWCT The Studio Entry Hill Bath BA2 5LY
Fabricator:	Ash and Lacy Bromford Lane West Bromwich West Midlands B70 7JJ
Installer:	Ash and Lacy Bromford Lane West Bromwich West Midlands B70 7JJ

Summary of results

Watertightness - dynamic: PASS
 Equivalent pressure: 600Pa

Note:

During the test some water passed through the mortar joints but this was insufficient to run down over the horizontal rails. No water reached the face of the back wall.

A drained and ventilated cavity would be required to remove any water that penetrates the brick slip system.

Flashings are required to drain water from the bottom of the cavity.

Wind resistance: PASS

Serviceability test pressure: 2400Pa

Maximum displacement under load 0.9mm and maximum residual displacement on unloading 0.1mm. Movement not visually discernible. This is less than the permitted deflection of brittle materials in the CWCT Standard of span/360.

Safety test pressure: 3600Pa

During the safety wind load test some minor cracking occurred to the mortar joints. This would not require remedial action.

Soft body impact test to CWCT
 Technical Note 76:

Serviceability
 No visible damage under a serviceability impact of 120Nm.
 This is designated as Class 1.

Safety
 Some cracking occurred to mortar joints under a safety impact test of 500Nm. This would not require immediate remedial action but cracking may allow further deterioration of mortar if exposed to severe weather.
 This is designated as negligible risk.

Hard body impact test to CWCT
 Technical Note 76:

Serviceability
 No visible damage under a serviceability impact of 6Nm.
 This is designated as Class 1.

Safety
 Vertical hairline cracks in brick slips and some cracking of mortar joints occurred under a safety impact of 10Nm. Brick slips remained secure.
 This is designated as negligible risk.

Drawings

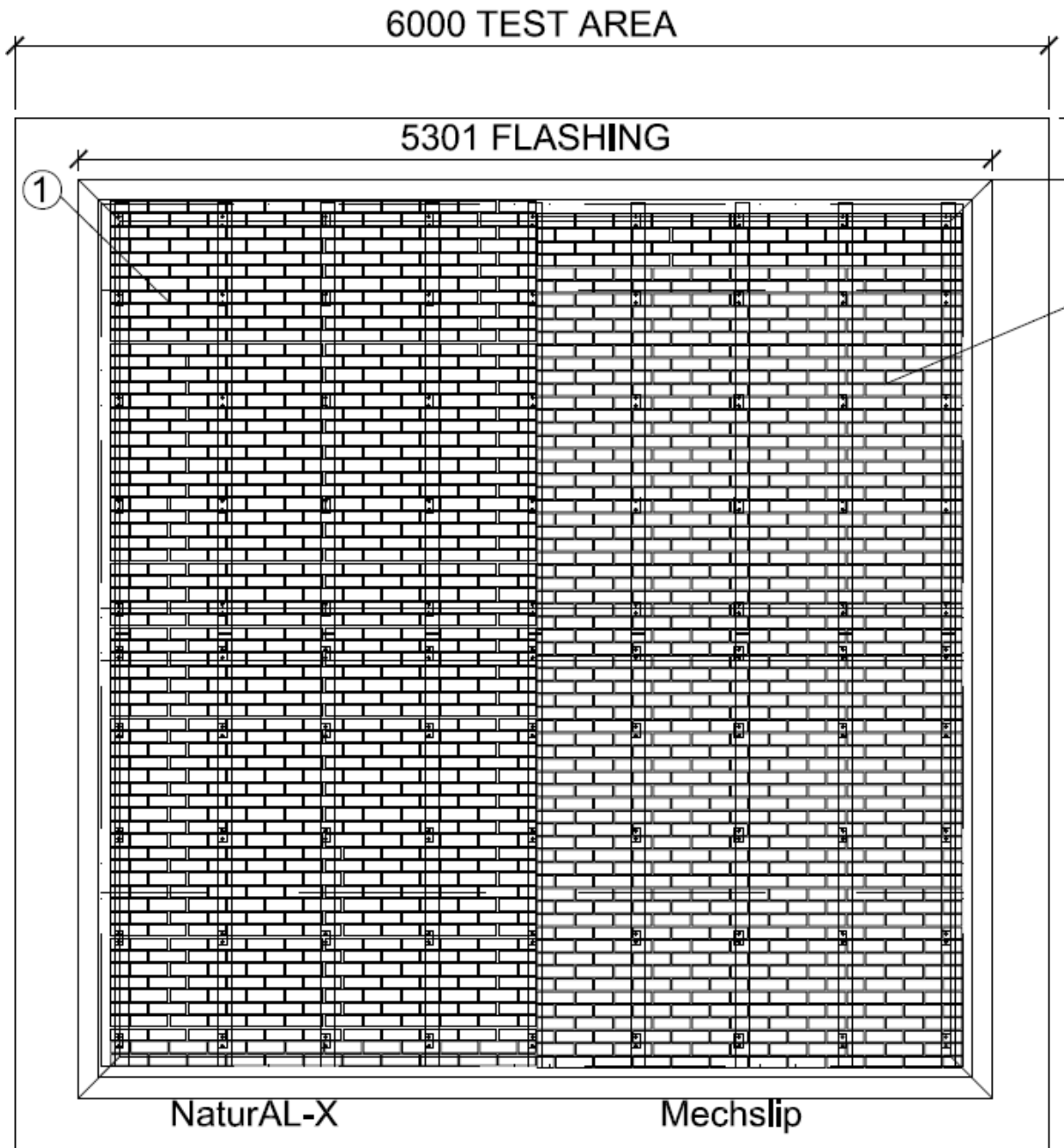

Elevation of test wall

Note: Test wall included two types of brick slip.
This certificate relates to the Mechslip system only.

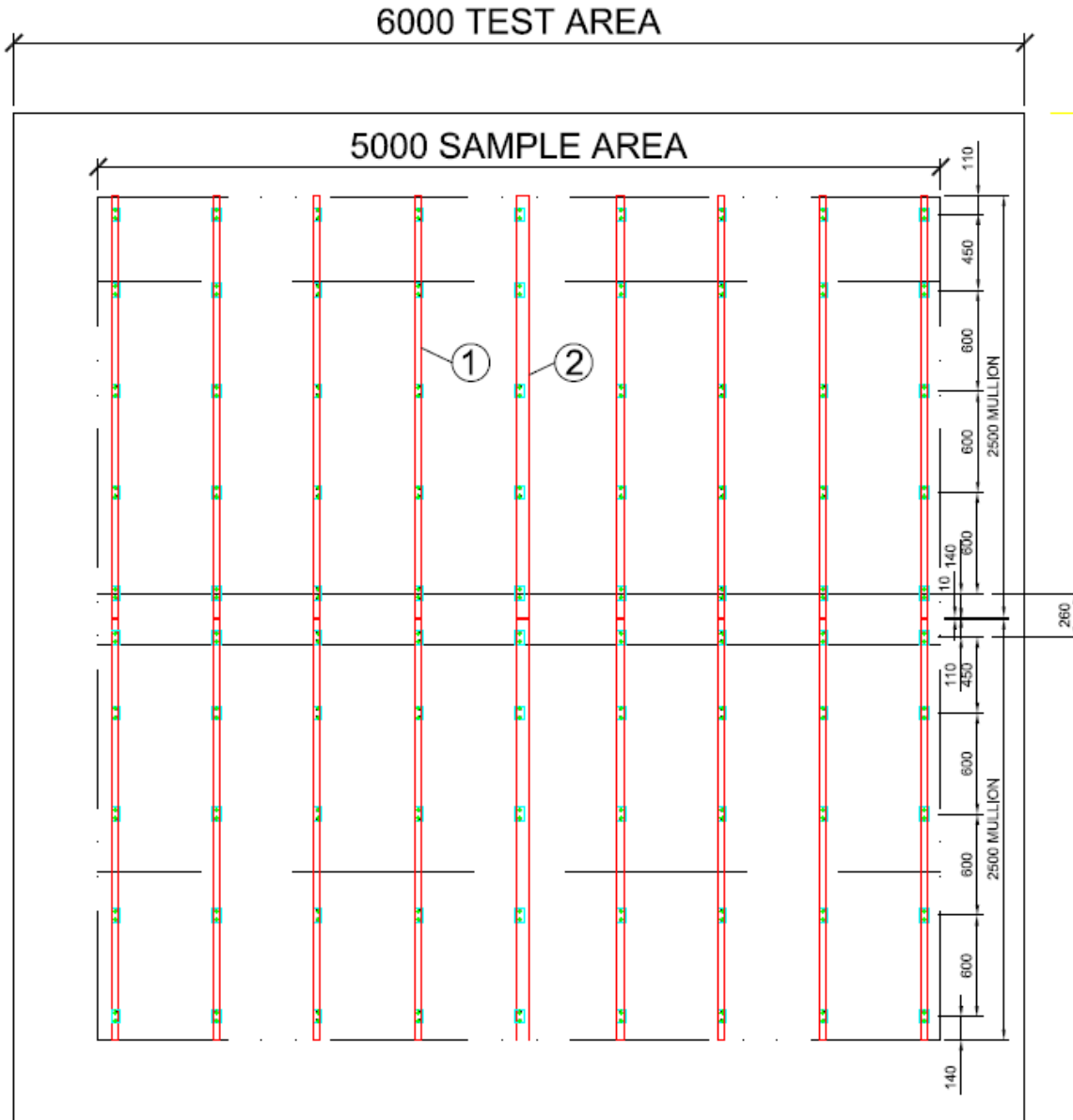

Key

1. 8 off M14 - L60X40X2.2 Rail, 2500 mm long
2. 2 off M15 - T60X80X2.2 Rail, 2500 mm long

Elevation of test wall showing support rails and bracket locations

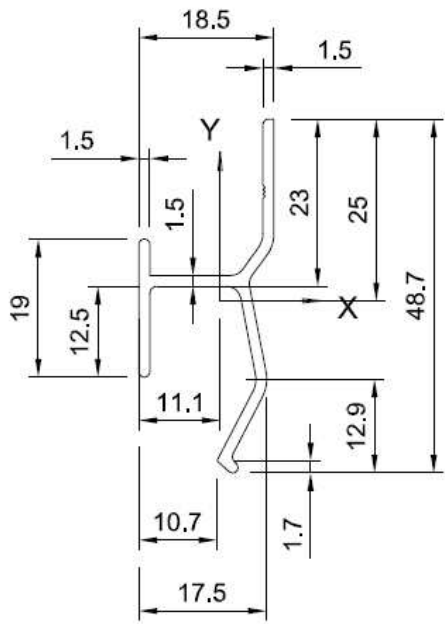

Horizontal rail

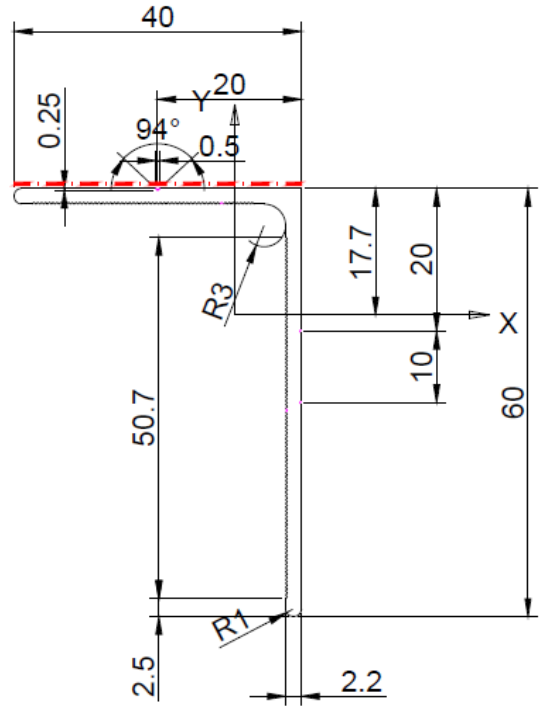

Vertical rail

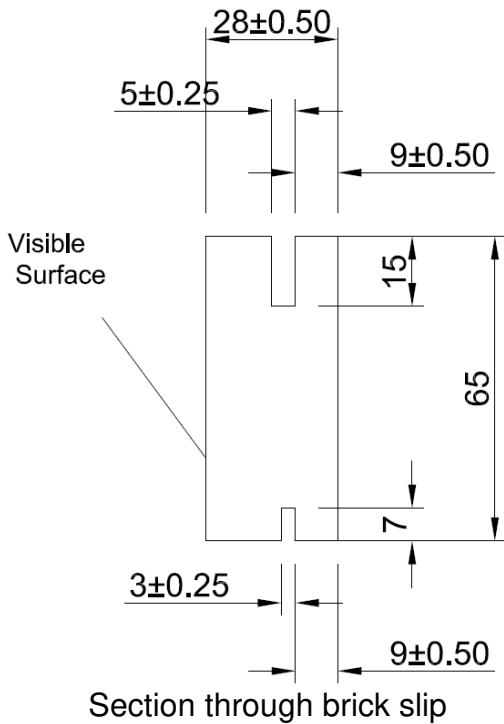

Section through brick slip

Component details

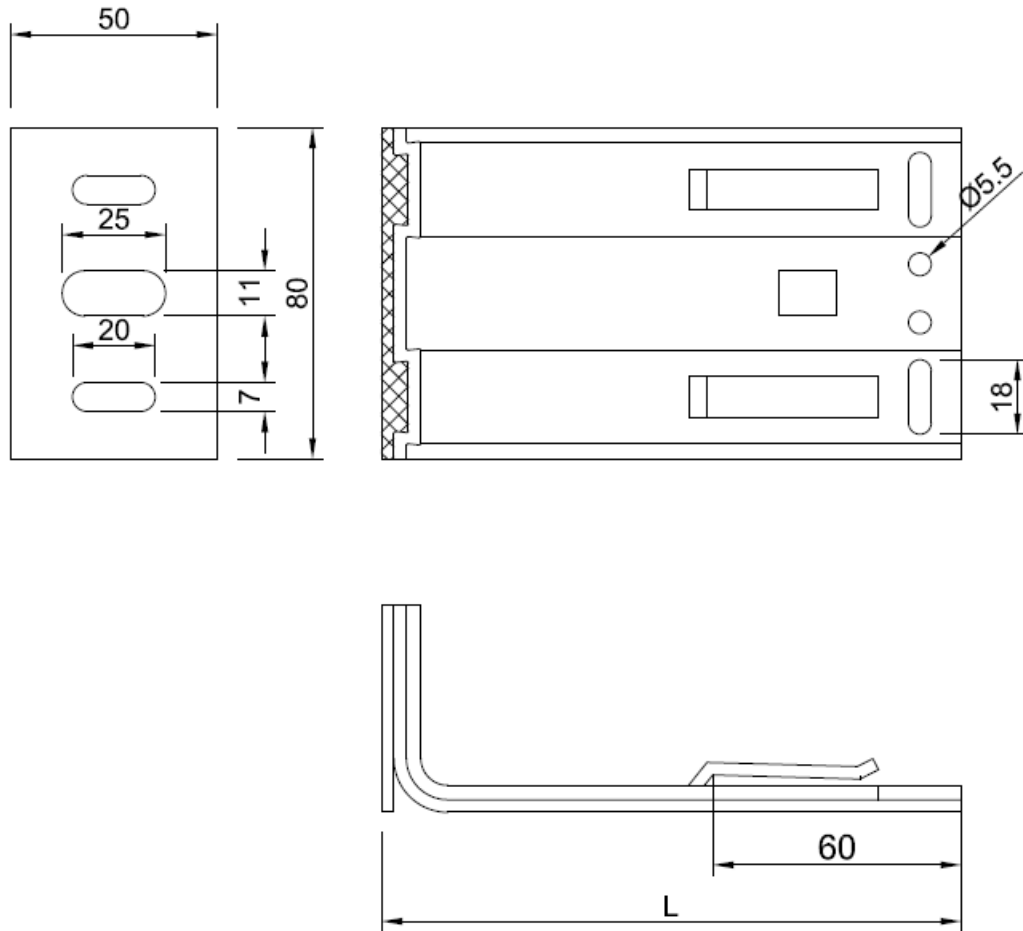

Bracket Ref	L (mm)	Components in Assembly
HB090S-TP	90	HB90S+TP80L
HB120S-TP	120	HB120S+TP80L
HB150S-TP	150	HB150S+TP80L
HB180S-TP	180	HB180S+TP80L
HB210S-TP	210	HB210S+TP80L
HB240S-TP	240	HB240S+TP80L
HB270S-TP	270	HB270S+TP80L
HB300S-TP	300	HB300S+TP80L

Bracket details

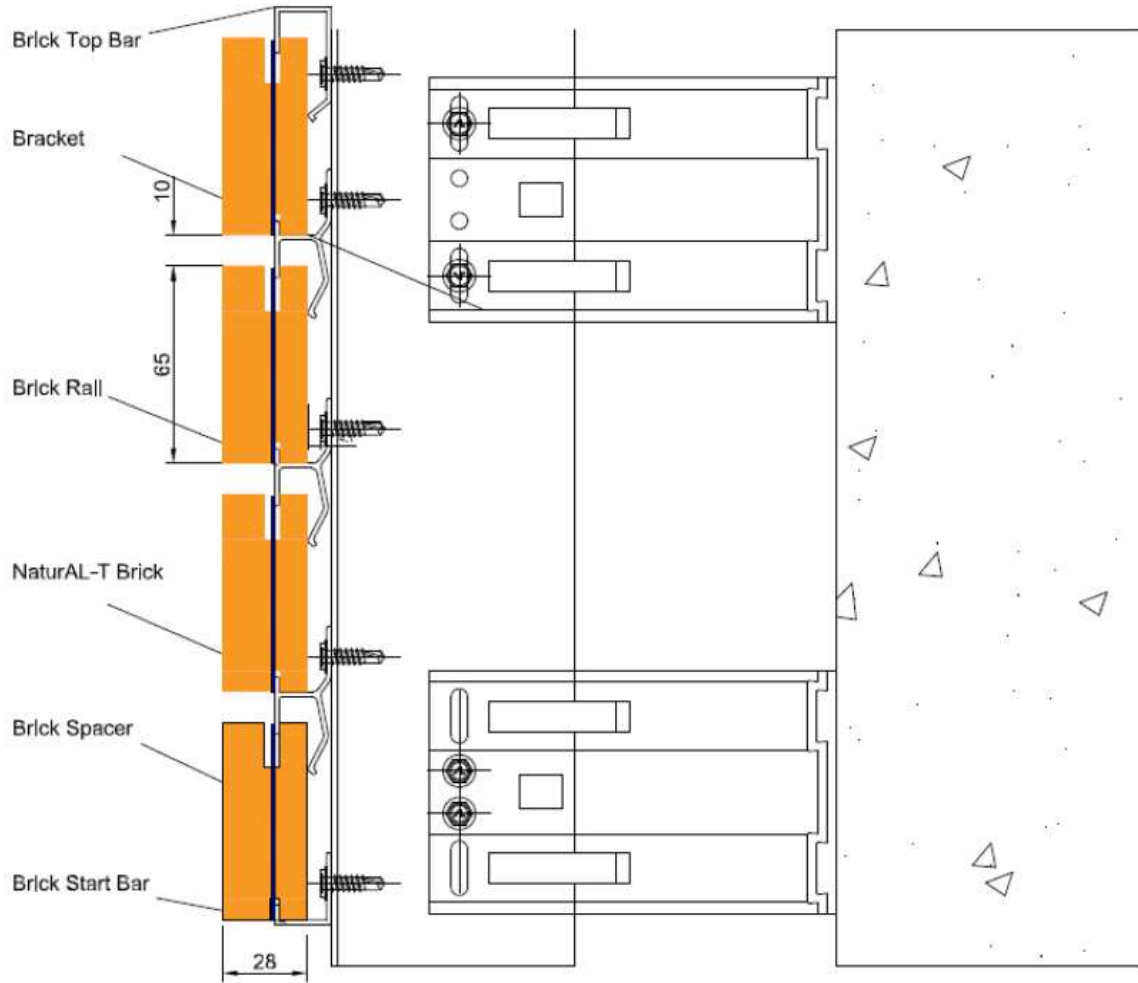

Section through system showing typical fixing arrangement